



Aerospace Industry

SKIN CLAMP RUNNER

Features:

- Ergonomic Handle
- Power Source: Compressed air
- Hose Size: 3/8" (10 mm)
- Air Inlet Size: 1/4 in (NPT)
- Inlet Pressure: 90 psig



SSR6P25



| Model Number | Free Speed | Weight | | Length | | Side To Center | | Air Consumption | | Sound Level |
|--------------|------------|--------|-----|--------|-----|----------------|----|-----------------|-----|-------------|
| | Rpm | lb | kg | in. | mm | in. | mm | cfm | l/s | dB(A) |
| SSR6P25 | 2500 | 2.7 | 1.2 | 9.2 | 234 | 0.9 | 23 | 30 | 14 | 78 |

RIVET SHAVERS

Features:

- Ergonomic Handle
- Power: 1 hp (0.75 kW)
- Recommended Hose Size: 3/8" (10 mm)
- Air Inlet Size: 1/4 in NPT
- Inlet Pressure: 90 psig



SRS10S21-8



SRS10P21-8

RIVET SHAVER SKIRTS

| Part Number | Cutter Diameter | |
|-------------|-----------------|----|
| | in | mm |
| 2925-5 | 5/16 | 8 |
| 2925-6 | 3/8 | 10 |
| 2925-7 | 7/16 | 11 |
| 2925-8B | 1/2 | 13 |
| 2925-9 | 9/16 | 14 |
| 2925-9W | 9/16 | 14 |
| 2925-10 | 5/8 | 16 |

| Model Number | Cutter Diameter | | Free Speed | Weight | | Length | | Side to Center | | Max Air Consumption | | Sound Level |
|---|-----------------|-----|------------|--------|-----|--------|-----|----------------|----|---------------------|------|-------------|
| | in | mm | rpm | lb | kg | in | mm | in | mm | cfm | l/s | dB(A) |
| 1 hp (0.75 kW) - Pistol Grip - 1/4" - 28 Internal Thread | | | | | | | | | | | | |
| SRS10P21-5 | 5/16 | 8 | 21,000 | 2.7 | 1.2 | 8.0 | 205 | 0.9 | 23 | 30 | 14.2 | 80 |
| SRS10P21-6 | 3/8 | 9.5 | 21,000 | 2.7 | 1.2 | 8.0 | 205 | 0.9 | 23 | 30 | 14.2 | 80 |
| SRS10P21-7 | 7/16 | 11 | 21,000 | 2.7 | 1.2 | 8.0 | 205 | 0.9 | 23 | 30 | 14.2 | 80 |
| SRS10P21-8 | 1/2 | 13 | 21,000 | 2.7 | 1.2 | 8.0 | 205 | 0.9 | 23 | 30 | 14.2 | 80 |
| SRS10P21-9 | 9/16 | 14 | 21,000 | 2.7 | 1.2 | 8.0 | 205 | 0.9 | 23 | 30 | 14.2 | 80 |
| SRS10P21-10 | 5/8 | 16 | 21,000 | 2.7 | 1.2 | 8.0 | 205 | 0.9 | 23 | 30 | 14.2 | 80 |
| 1 hp (0.75 kW) - Inline - 1/4" - 28 Internal Thread | | | | | | | | | | | | |
| SRS10S21-8 | 1/2 | 13 | 21,000 | 2.5 | 1.1 | 10.0 | 255 | 0.9 | 23 | 30 | 14.2 | 78 |

SIGNATURE SERIES ROUTERS

- Features:**
- Lockoff Lever Throttle
 - Front Exhaust
 - Interchangeable Base
 - Built-in Speed Control
 - Power: 1.0 hp (0.75 kW)

| Model Number | Collet Size | Free Speed rpm | Weight | | Height | | Maximum Air Consumption | | Sound Level dB(A) |
|----------------------|-------------|----------------|--------|------|--------|-----|-------------------------|-----|-------------------|
| | | | lb | kg | in | mm | scfm | l/s | |
| Template Nose | | | | | | | | | |
| SRT10S25N | 1/4 | 25,000 | 2.1 | 0.95 | 9.0 | 230 | 30 | 14 | 78 |
| SRT10S18N | 1/4 | 18,000 | 2.1 | 0.95 | 9.0 | 230 | 30 | 14 | 78 |
| 3" Base | | | | | | | | | |
| SRT10S25B | 1/4 | 25,000 | 2.1 | 0.95 | 9.0 | 230 | 30 | 14 | 78 |
| SRT10S18B | 1/4 | 18,000 | 2.1 | 0.95 | 9.0 | 230 | 30 | 14 | 78 |
| SRT10S25BB | 1/4 | 25,000 | 2.6 | 1.15 | 8.3 | 210 | 30 | 14 | 78 |
| SRT10S18BB | 1/4 | 18,000 | 2.6 | 1.15 | 8.3 | 210 | 30 | 14 | 78 |



AIR HAMMER

- Features:**
- Pistol Grip
 - Teasing Throttle Trigger Start
 - Accepts .401 Parker Taper Rivet Sets and Chisels
 - Power Source: Compressed Air
 - Air Inlet Size: 1/4 in (NPT)
 - Inlet Pressure: 90 psig
 - Recommended Hose Size: 3/8 in
 - Air Consumption (Max): 8.0 cfm
 - Bore Diameter: 0.6 in



270A-2

| Catalog Number | Steel Rivet Capacity | Stroke Length | Blows per Minute | Length | Weight |
|----------------|----------------------|---------------|------------------|--------|--------|
| 270A | 3/16 in | 3.0 in | 2000 | 3.2 lb | 6.8 in |
| 270A-2 | 5/32 in | 2.0 in | 2500 | 3.0 lb | 5.8 in |
| 270A-4 | 1/4 in | 4.0 in | 1700 | 3.5 lb | 7.8 in |

Sioux-per Swivel



1338-25

1338FC-25

| Part Number | Description |
|-------------|---|
| 1338-25 | 1/4" non-regulated air swivel connector with safety pin |
| 1338-38 | 3/8" non-regulated air swivel connector with safety pin |
| 1338-50 | 1/2" non-regulated air swivel connector with safety pin |
| 1338FC-25 | 1/4" regulated air swivel connector with safety pin |

MINATURE ANGLE DRILL

- Features:**
- Non-reversible
 - Lever Start
 - Rear Exhaust
 - Comfort Grip
 - Power Source: Compressed air
 - Hose Size: 1/4" (6mm)
 - 3/8" (10mm) (1AM Kit series)
 - Air Inlet Size: 1/4 in (NPT)
 - Inlet Pressure: 90 psig



1AM1541



1AM1552

Optional Internal Threads:
1/4-28, 9/32-40

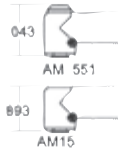

SEALANT REMOVAL TOOL KIT

- Features:**
- Carrying Case
 - 3MTM #8 (.83") SR Cutters
 - 3MTM #3 (.40") SR Cutters
 - SR40 Tube of 5 #3 SR Cutters
 - SR83 Tube of 5 #8 SR Cutters
 - Includes 1AM1151 (90° Angle Drill) and 65213 (45° Angle Drill Head Assembly)



1AM1141/51K



| Model Number | Free Speed Rpm | Weight | | Length | | Side To Center | | Air Consumption | | Sound Level dB(A) |
|--|----------------|--------|-----|--------|-----|----------------|----|-----------------|-----|-------------------|
| | | lb | kg | in. | mm | in. | mm | cfm | l/s | |
| 45° Angle Head - 0.33 hp (0.25 kW) - 1/4"-28 Internal Thread Spindle | | | | | | | | | | |
| 1AM1541 | 2800 | 1.5 | 0.7 | 10.2 | 259 | 0.3 | 8 | 12 | 6 | 75 |
| 90° Angle Head - 0.33 hp (0.25 kW) - 1/4"-28 Internal Thread Spindle | | | | | | | | | | |
| 1AM1551 | 2800 | 1.5 | 0.7 | 9.7 | 246 | 0.3 | 8 | 12 | 6 | 75 |
| 90° Angle Head - 0.33 hp (0.25 kW) - 9/32"-40 Internal Thread Spindle | | | | | | | | | | |
| 1AM1552 | 2800 | 1.5 | 0.7 | 9.7 | 246 | 0.3 | 8 | 12 | 6 | 75 |
| 1AM1452 | 2200 | 1.5 | 0.7 | 9.7 | 246 | 0.3 | 8 | 12 | 6 | 75 |
| Sealant Removal Tool Kit | | | | | | | | | | |
| 1AM1141/51K | 800 | 1.8 | .8 | 11.5 | 292 | 0.3 | 8 | 12 | 6 | 75 |

Includes 1AM1151 (90° Angle Drill) and 65213 (45° Angle Drill Head Assembly)

www.dobcoeqp.com sales@dobcoeqp.com 905-672-5557

DOBCO EQUIPMENT LTD. 905-672-5557 sales@dobcoeqp.com www.dobcoeqp.com

SIGNATURE SERIES DRILLS

Features:

- Available keyed or keyless chuck
- 3 planet gear system for increased life and load capacity
- Planetary gear reduction assembly can be serviced without removing the chuck
- Ring gear—machined into the motor retainer for ease of assembly and disassembly
- Rotor pinion is case hardened to resist wear
- Rotor, cylinder and endplates are interchangeable between different models. This reduces the number of spare parts tool cribs need to stock.
- Tipper valve and valve seat are easily accessible for service.
- Ball bearing construction throughout
- Precision machined steel motor
- Teasing throttle
- Cast aluminum handle with comfort Grip
- Power Source: Compressed air
- Hose Size: 1/4" (6mm)
- Air Inlet Size: 1/4 in (NPT)
- Inlet Pressure: 90 psig



SDR10P60N3



SDR10P3R3



SDR10P26N2



SDR6P26N2

| Model Number | Free Speed | Chuck Capacity | | Weight | | Length | | Air Consumption | | Sound Level | Spindle Thread |
|--|------------|----------------|----|--------|-----|--------|------|-----------------|------|-------------|----------------|
| | Rpm | in. | mm | lb | kg | in. | mm | scfm | l/s | dB(A) | |
| Pistol Grip Non-Reversing Drills - 1.0 hp (0.75 kW) | | | | | | | | | | | |
| SDR10P60N2 | 6,000 | 1/4 | 6 | 7.6 | 193 | 2.31 | 1.05 | 30 | 14.2 | 80 | 3/8" 24 |
| SDR10P60N3 | 6,000 | 3/8 | 10 | 8.1 | 206 | 2.45 | 1.11 | 30 | 14.2 | 80 | 3/8" 24 |
| SDR10P40N2 | 4,000 | 1/4 | 6 | 7.6 | 193 | 2.31 | 1.05 | 30 | 14.2 | 80 | 3/8" 24 |
| SDR10P26N2 | 2,600 | 1/4 | 6 | 7.6 | 193 | 2.31 | 1.05 | 30 | 14.2 | 80 | 3/8" 24 |
| SDR10P12N3 | 1,200 | 3/8 | 10 | 9.1 | 231 | 2.88 | 1.30 | 30 | 14.2 | 80 | 3/8" 24 |
| SDR10P4N4 | 400 | 1/2 | 13 | 9.6 | 244 | 3.33 | 1.51 | 30 | 14.2 | 80 | 1/2" 20 |
| Pistol Grip Reversing Drill - 1.0 hp (0.75 kW) | | | | | | | | | | | |
| SDR10P3R3 | 300 | 3/8 | 10 | 9.7 | 246 | 3.12 | 1.47 | 30 | 14.2 | 80 | 1/2" 20 |
| Pistol Grip Non-Reversing Drills - 0.6 hp (0.45 kW) | | | | | | | | | | | |
| SDR6P60N2 | 6,000 | 1/4 | 6 | 6.9 | 175 | 2.12 | .096 | 25 | 11.8 | 80 | 3/8" 24 |
| SDR6P40N2 | 4,000 | 1/4 | 6 | 6.9 | 175 | 2.12 | .096 | 25 | 11.8 | 80 | 3/8" 24 |
| SDR6P26N2 | 2,600 | 1/4 | 6 | 6.9 | 175 | 2.12 | .096 | 25 | 11.8 | 80 | 3/8" 24 |

Signature Series Drill Features

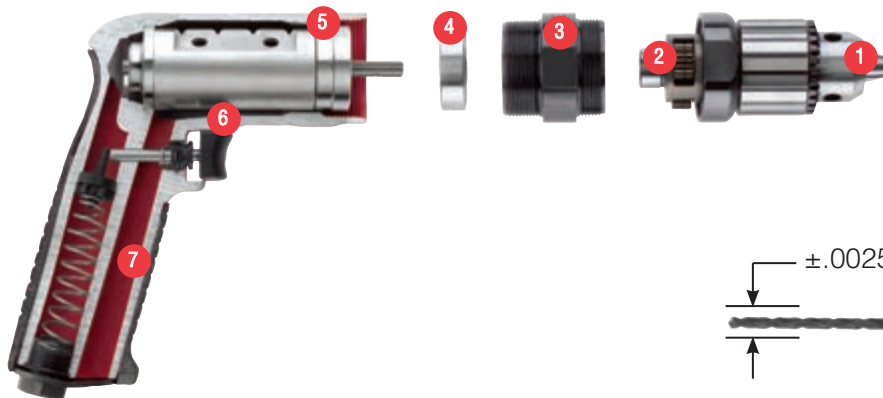

- 1 Available keyed or keyless chuck
- 2 3 planet gear system for increased life and load capacity
- 3 Ring gear
- 4 Ball bearing construction throughout
- 5 Precision machined steel motor
- 6 Teasing throttle
- 7 Cast aluminum handle with comfort grip

Runout

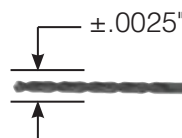

±.0025" Runout at 2-1/2" from end of chuck

Serviceability

- Ring gear is machined into the motor retainer for ease of assembly and disassembly.
- Planetary gear reduction assembly can be serviced without removing the chuck.
- Rotor pinion is case hardened to resist wear.
- Rotor, cylinder and endplates are interchangeable between different models. This reduces the number of spare parts tool cribs need to stock.
- Tipper valve and valve seat are easily accessible for service.

HIGH SPEED DRILL

Features:

- Non-reversible
- Trigger start
- Rapid Reverse
- Comfort Grip
- Power Source: Compressed air

- Hose Size: 1/4 in (6mm)
- Air Inlet Size: 1/4 in (NPT)
- Inlet Pressure: 90 psig
- Control Type: On/Off
- Handle Type: Pistol Grip
- Length: 6.3 in
- Power: 0.33 hp (0.25 kW)
- Noise Level: 75 dB



DR1412

| Model Number | Chuck Size | Free Speed | Spindle Size | Air Consumption (Max) |
|--------------|------------|------------|--------------|-----------------------|
| DR1412 | 1/4 in | 3600 rpm | 3/8"-24 | 12 cfm |
| 1410 | 1/4 in | 2600 rpm | 3/8"-24 | 12 cfm |

RIGHT ANGLE DIE GRINDERS

Features:

- Powerful 5 vane motors deliver high working speeds
- Heavy duty double tapered collet
- Teasing throttle for maximum control
- Lever throttle with lock-off
- Ball bearing construction
- Heavy Duty spiral bevel gearing for durability and smooth operation
- Compact angle head allows access into tight spaces
- Adjustable speed control
- Grease zerk in gear case



SAG05S23



SAG03S20

| Model Number | Free Speed | Weight | | Length | | Sound Level | Air Consumption | | Collet Size | Exhaust |
|---|------------|--------|------|--------|-----|-------------|-----------------|------|-------------|---------|
| | rpm | lb | kg | in | mm | dB(A) | scfm | l/s | | |
| 0.30 hp (0.22 kW) - Lever Throttle | | | | | | | | | | |
| SAG03S20 | 20,000 | 1.2 | 0.55 | 5.625 | 140 | 86.4 | 11 | 5.2 | 1/4" | Rear |
| SAG03S12 | 12,000 | 1.2 | 0.55 | 5.625 | 140 | 81.5 | 11 | 5.2 | 1/4" | Rear |
| 0.30 hp (0.22 kW) - Lever Throttle - 300 Series Collet | | | | | | | | | | |
| SAG03S12S | 12,000 | 1.15 | 0.52 | 5.625 | 143 | 82.3 | 11 | 5.2 | 1/4" | Rear |
| SAG03S20S | 20,000 | 1.15 | 0.52 | 5.625 | 143 | 85.9 | 11 | 5.2 | 6mm | Rear |
| 0.50 hp (0.37 kW) - Lever Throttle | | | | | | | | | | |
| SAG05S23 | 23,000 | 1.4 | 0.64 | 6.375 | 160 | 86 | 23 | 10.8 | 1/4" | Rear |
| 0.50 hp (0.37 kW) - Lever Throttle - 300 Series Collet | | | | | | | | | | |
| SAG05S23S | 23,000 | 1.35 | 0.61 | 6.375 | 162 | 89.1 | 23 | 10.8 | 1/4" | Rear |

Straight and Extended Die Grinders

Features:

- Powerful 5 vane motors deliver high working speeds
- Heavy duty double tapered collet
- Ergonomic comfort grip
- Teasing throttle for maximum control
- Lever throttle with lock-off
- Ball bearing construction
- Adjustable speed control



SDG03S25



SDG05S23



SXG05S23

| Model Number | Free Speed | Weight | | Length | | Sound Level | Air Consumption | | Collet Size | Exhaust |
|--|------------|--------|------|--------|-----|-------------|-----------------|------|-------------|---------|
| | rpm | lb | kg | in | mm | dB(A) | scfm | l/s | | |
| 0.30 hp (0.22 kW) - Lever Throttle - 200 Series Collet | | | | | | | | | | |
| SDG03S25 | 25,000 | 1.0 | 0.45 | 6.25 | 160 | 84.3 | 11 | 5.2 | 1/4" | Rear |
| 0.30 hp (0.22 kW) - Lever Throttle - 300 Series Collet | | | | | | | | | | |
| SDG03S25S | 25,000 | 1.0 | 0.45 | 6.25 | 160 | 83.3 | 11 | 5.2 | 1/4" | Rear |
| 0.50 hp (0.37 kW) - Lever Throttle - 200 Series Collet | | | | | | | | | | |
| SDG05S23 | 23,000 | 1.2 | 0.54 | 7.0 | 180 | 87.7 | 23 | 10.9 | 1/4" | Rear |
| 0.50 hp (0.37 kW) - Lever Throttle - 300 Series Collet | | | | | | | | | | |
| SDG05S23S | 23,000 | 1.2 | 0.54 | 7.0 | 180 | 85.1 | 23 | 10.9 | 1/4" | Rear |
| 0.50 hp (0.37 kW) - Lever Throttle - Extended - 200 Series Collet | | | | | | | | | | |
| SXG05S23 | 23,000 | 2.1 | 0.95 | 11 | 280 | 89.8 | 23 | 10.9 | 1/4" | Rear |
| 0.50 hp (0.37 kW) - Lever Throttle - Extended - 300 Series Collet | | | | | | | | | | |
| SXG05S23S | 23,000 | 2.1 | 0.95 | 11 | 280 | 85.9 | 23 | 10.9 | 1/4" | Rear |

RANDOM ORBITAL SANDERS

Features:

- Ergonomic 24-position indexable grip
- Built in speed control
- Color coded lock rings identify orbit size
- Naturally contoured power lever



RO2512-50SNP

RO2512-50SRP

RO2512-50FVP

| Model Number | | Free Speed rpm | Pad Size | | Orbit Diameter | | Weight | | Height | | Air Consumption Free Speed | | Sound Level dB(A) |
|---|--------------|-------------------|----------|-----|----------------|----|--------|-----|--------|----|----------------------------|-----|----------------------|
| PSA Pad | H & L Pad | | in | mm | in | mm | lb | kg | in | mm | cfm | l/s | |
| 0.25 hp (0.19 kW) - 5/16 - 24 Spindle Thread - Non-Vacuum | | | | | | | | | | | | | |
| RO2512-30FNP | RO2512-30FNH | 12,000 | 3 | 75 | 3/32 | 3 | 1.5 | 0.7 | 3.3 | 83 | 13 | 6 | 81 |
| RO2512-30SNP | RO2512-30SNH | 12,000 | 3 | 75 | 3/16 | 5 | 1.5 | 0.7 | 3.3 | 83 | 13 | 6 | 81 |
| RO2512-35FNP | RO2512-35FNH | 12,000 | 3.5 | 90 | 3/32 | 3 | 1.5 | 0.7 | 3.3 | 83 | 13 | 6 | 81 |
| RO2512-35SNP | RO2512-35SNH | 12,000 | 3.5 | 90 | 3/16 | 5 | 1.5 | 0.7 | 3.3 | 83 | 13 | 6 | 81 |
| RO2512-50FNP | RO2512-50FNH | 12,000 | 5 | 125 | 3/32 | 3 | 1.5 | 0.7 | 3.3 | 83 | 13 | 6 | 81 |
| RO2512-50SNP | RO2512-50SNH | 12,000 | 5 | 125 | 3/16 | 5 | 1.5 | 0.7 | 3.3 | 83 | 13 | 6 | 81 |
| RO2512-50CNP | RO2512-50CNH | 12,000 | 5 | 125 | 3/8 | 10 | 1.5 | 0.7 | 3.3 | 83 | 13 | 6 | 81 |
| RO2512-60FNP | RO2512-60FNH | 12,000 | 6 | 150 | 3/32 | 3 | 1.5 | 0.7 | 3.3 | 83 | 13 | 6 | 81 |
| RO2512-60SNP | RO2512-60SNH | 12,000 | 6 | 150 | 3/16 | 5 | 1.5 | 0.7 | 3.3 | 83 | 13 | 6 | 81 |
| RO2512-60CNP | RO2512-60CNH | 12,000 | 6 | 150 | 3/8 | 10 | 1.5 | 0.7 | 3.3 | 83 | 13 | 6 | 81 |
| 0.25 hp (0.19 kW) - 5/16 - 24 Spindle Thread - Remote Vacuum Ready | | | | | | | | | | | | | |
| RO2512-30FRP | RO2512-30FRH | 12,000 | 3 | 75 | 3/32 | 3 | 1.5 | 0.7 | 3.3 | 83 | 13 | 6 | 81 |
| RO2512-30SRP | RO2512-30SRH | 12,000 | 3 | 75 | 3/16 | 5 | 1.5 | 0.7 | 3.3 | 83 | 13 | 6 | 81 |
| RO2512-35FRP | RO2512-35FRH | 12,000 | 3.5 | 90 | 3/32 | 3 | 1.5 | 0.7 | 3.3 | 83 | 13 | 6 | 81 |
| RO2512-35SRP | RO2512-35SRH | 12,000 | 3.5 | 90 | 3/16 | 5 | 1.5 | 0.7 | 3.3 | 83 | 13 | 6 | 81 |
| RO2512-50FRP | RO2512-50FRH | 12,000 | 5 | 125 | 3/32 | 3 | 1.5 | 0.7 | 3.3 | 83 | 13 | 6 | 81 |
| RO2512-50SRP | RO2512-50SRH | 12,000 | 5 | 125 | 3/16 | 5 | 1.5 | 0.7 | 3.3 | 83 | 13 | 6 | 81 |
| RO2512-50CRP | RO2512-50CRH | 12,000 | 5 | 125 | 3/8 | 10 | 1.5 | 0.7 | 3.3 | 83 | 13 | 6 | 81 |
| RO2512-60FRP | RO2512-60FRH | 12,000 | 6 | 150 | 3/32 | 3 | 1.5 | 0.7 | 3.3 | 83 | 13 | 6 | 81 |
| RO2512-60SRP | RO2512-60SRH | 12,000 | 6 | 150 | 3/16 | 5 | 1.5 | 0.7 | 3.3 | 83 | 13 | 6 | 81 |
| RO2512-60CRP | RO2512-60CRH | 12,000 | 6 | 150 | 3/8 | 10 | 1.5 | 0.7 | 3.3 | 83 | 13 | 6 | 81 |
| 0.25 hp (0.19 kW) - 5/16 - 24 Spindle Thread - Self-contained Venturi Vacuum | | | | | | | | | | | | | |
| RO2512-30FVP | RO2512-30FVH | 12,000 | 3 | 75 | 3/32 | 3 | 1.5 | 0.7 | 3.3 | 83 | 13 | 6 | 81 |
| RO2512-30SVP | RO2512-30SVH | 12,000 | 3 | 75 | 3/16 | 5 | 1.5 | 0.7 | 3.3 | 83 | 13 | 6 | 81 |
| RO2512-35FVP | RO2512-35FVH | 12,000 | 3.5 | 90 | 3/32 | 3 | 1.5 | 0.7 | 3.3 | 83 | 13 | 6 | 81 |
| RO2512-35SVP | RO2512-35SVH | 12,000 | 3.5 | 90 | 3/16 | 5 | 1.5 | 0.7 | 3.3 | 83 | 13 | 6 | 81 |
| RO2512-50FVP | RO2512-50FVH | 12,000 | 5 | 125 | 3/32 | 3 | 1.5 | 0.7 | 3.3 | 83 | 13 | 6 | 81 |
| RO2512-50SVP | RO2512-50SVH | 12,000 | 5 | 125 | 3/16 | 5 | 1.5 | 0.7 | 3.3 | 83 | 13 | 6 | 81 |
| RO2512-50CVP | RO2512-50CVH | 12,000 | 5 | 125 | 3/8 | 10 | 1.5 | 0.7 | 3.3 | 83 | 13 | 6 | 81 |
| RO2512-60FVP | RO2512-60FVH | 12,000 | 6 | 150 | 3/32 | 3 | 1.5 | 0.7 | 3.3 | 83 | 13 | 6 | 81 |
| RO2512-60SVP | RO2512-60SVH | 12,000 | 6 | 150 | 3/16 | 5 | 1.5 | 0.7 | 3.3 | 83 | 13 | 6 | 81 |
| RO2512-60CVP | RO2512-60CVH | 12,000 | 6 | 150 | 3/8 | 10 | 1.5 | 0.7 | 3.3 | 83 | 13 | 6 | 81 |

ORBITAL JITTERBUG SANDERS

Features:

- Built-in Speed Control
- Ergonomic 24-Position Indexable Grip
- Power: 0.25 hp (0.19 kW)
- Speed: 10,000 rpm



RO2510-44FNC

| Model Number | Paper Size | | Orbit Diameter | | Weight | | Height | | Air Consumption Free Speed | | Sound Level dB(A) |
|--------------------------|---------------|----------|----------------|----|--------|-----|--------|----|----------------------------|-----|----------------------|
| | in | mm | in | mm | lb | kg | in | mm | cfm | l/s | |
| .025 hp (0.19 kW) | | | | | | | | | | | |
| RO2510-44FNC | 3-3/4 x 4-1/4 | 95 x 105 | 3/32 | 3 | 1.8 | 0.8 | 3.5 | 90 | 13 | 6 | 81 |

GEARED ORBITAL SANDERS

Features:

- 3/16" (5 mm) Orbit Diameter
- Built-in Speed Control
- Lever Throttle
- Vacuum & Remote Vacuum
- Ergonomic 24-Position Indexable Grip
- Power: 0.45 hp (0.34 kW)
- Speed: 900 rpm



GO459-80SRP

GO459-60SNP

| Model Number | | Free Speed rpm | Pad Size | | Weight | | Height | | Air Consumption Free Speed | | Sound Level dB(A) |
|---------------------------------------|-------------|-------------------|----------|-----|--------|-----|--------|-----|----------------------------|-----|----------------------|
| PSA Pad | H & L Pad | | in | mm | lb | kg | in | mm | cfm | l/s | |
| .45 HP (0.34 kW) Non-Vacuum | | | | | | | | | | | |
| GO459-60SNP | GO459-60SNH | 900 | 6 | 150 | 4.4 | 2.0 | 5 | 127 | 15 | 7 | 82 |
| GO459-80SNP | GO459-80SNH | 900 | 8 | 200 | 4.4 | 2.0 | 5 | 127 | 15 | 7 | 82 |
| .45 HP (0.34 kW) Remote Vacuum | | | | | | | | | | | |
| GO459-60SRP | GO459-60SRH | 900 | 6 | 150 | 4.4 | 2.0 | 5 | 127 | 15 | 7 | 82 |
| GO459-80SRP | GO459-80SRH | 900 | 8 | 200 | 4.4 | 2.0 | 5 | 127 | 15 | 7 | 82 |

CLINCH NUT TOOLS

Features:

- Reversible
- Pistol Grip
- 1 hp (0.75 kW)
- Torque: 60 in. lb (6.5 Nm) - 400 in. lb (45 Nm)
- Speed: 300 rpm - 2500 rpm

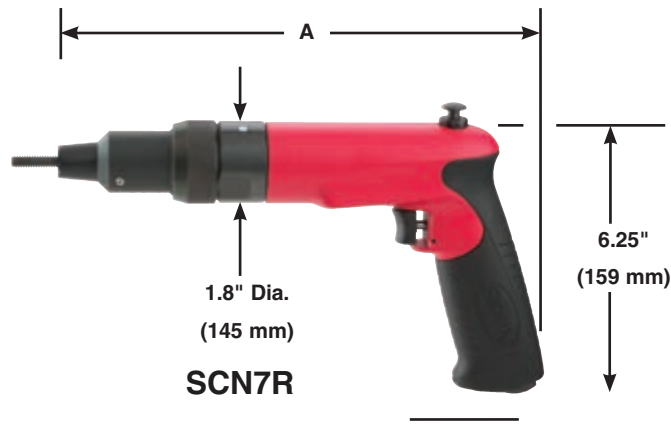

SCN7R

| Model Number | Free Speed | Maximum Torque | | Weight | | "A" Dimension | | Side To Center | | Maximum Air Consumption | | Sound Level |
|---|------------|----------------|------|--------|-----|---------------|-----|----------------|----|-------------------------|-----|-------------|
| | rpm | in lb | Nm | lb | kg | in | mm | in | mm | scfm | l/s | dB(A) |
| Pistol Grip - Rapid Reverse - Power Units Specifications | | | | | | | | | | | | |
| SCN3R | 300 | 400 | 45.2 | 3.2 | 1.5 | 11.0 | 279 | 0.9 | 20 | 30 | 14 | 80 |
| SCN5R | 500 | 325 | 36.7 | 3.2 | 1.5 | 11.0 | 279 | 0.9 | 20 | 30 | 14 | 80 |
| SCN7R | 700 | 220 | 24.8 | 3.2 | 1.5 | 11.0 | 279 | 0.9 | 20 | 30 | 14 | 80 |
| SCN12R | 1200 | 145 | 16.4 | 3.2 | 1.5 | 11.0 | 279 | 0.9 | 20 | 30 | 14 | 80 |
| SCN20R | 2000 | 80 | 9.0 | 2.8 | 1.3 | 10.0 | 254 | 0.9 | 20 | 30 | 14 | 80 |
| SCN25R | 2500 | 60 | 6.5 | 2.8 | 1.3 | 10.0 | 254 | 0.9 | 20 | 30 | 14 | 80 |

Power units can be ordered separately using part number above. For ordering complete tools select the appropriate power unit from the chart above and head assembly from the chart below and combine their part numbers as shown in the following example: SCN3R420.

Clinch Nut (Female)



| Thread Size | Order Number Suffix | |
|-------------|---------------------|-------------|
| | Serrated Nose | Smooth Nose |
| #4-40 | 440 | 440S |
| M3 x 0.5 | M305 | M305S |
| #6-32 | 632 | 632S |
| #8-32 | 832 | 832S |
| M4 x 0.7 | M407 | M407S |
| #10-24 | 1024 | 1024S |
| #10-32 | 1032 | 1032S |
| M5 x 0.8 | M508 | M508S |
| 1/4-20 | 420 | 420S |
| M6 x 1.0 | M610 | M610S |
| 5/16-18 | 518 | 518S |
| M8 x 1.25 | M8125 | M8125S |
| 3/8-16 | 616 | 616S |
| M10 x 1.5 | M1015 | M1015S |

Clinch Stud (Male)

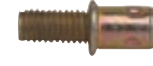

| Thread Size | Order Number Suffix | |
|-------------|---------------------|-------------|
| | Serrated Nose | Smooth Nose |
| #4-40 | 440F | 440SF |
| M3 x 0.5 | M305F | M305SF |
| #6-32 | 632F | 632SF |
| #8-32 | 832F | 832SF |
| M4 x 0.7 | M407F | M407SF |
| #10-24 | 1024F | 1024SF |
| #10-32 | 1032F | 1032SF |
| M5 x 0.8 | M508F | M508SF |
| 1/4-20 | 420F | 420SF |
| M6 x 1.0 | M610F | M610SF |
| 5/16-18 | 518F | 518SF |
| M8 x 1.25 | M8125F | M8125SF |
| 3/8-16 | 616F | 616SF |
| M10 x 1.5 | M1015F | M1015SF |

Clinch Nut Installation Procedure

Step 1 - Pre-drill hole for fastener.

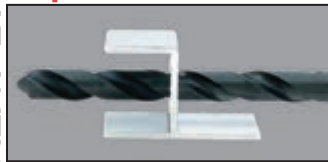

Step 4 - Run tool to collapse fastener. Reverse tool to release.



Step 2 - Insert fastener.

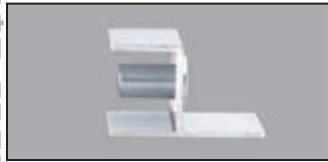

Step 5 - Assemble.



Step 3 - Thread tool into fastener.



Sioux Tool's new rapid reverse Clinch Nut Tools are meeting the demand of today's manufacturing marketplace with versatility and simplicity. Clinch nuts, also known as captive nuts, provide a reliable means of securing assembly components in thin wall applications. These unique fasteners are inserted into predrilled holes in thin materials such as sheet metal, and with the aid of a Sioux Clinch Nut Tool, compress and expand to clamp the material. This process creates a strong, secure base with a male or female thread for assembling additional components.

Installing Clinch Nut Fasteners

When installing clinch nut fasteners, the key to achieving high productivity with accurate, repeatable results is matching the right tool and fastener to your application. The right combination of rundown speed and stall torque in conjunction with a quick reverse method for disengaging the tool, will provide the best results. The Sioux SCN series tools offer higher torque in a wide range of speeds so you can match the right tool to your application. Our powerful tools allow you to use faster rundown speeds while maintaining high torque output, plus our exclusive Rapid Reverse feature makes short work of direction changes ensuring fast disengagement from the fastener.

Reducing Physical Load

The ergonomic pistol housing with comfort rubber grip ensures operator comfort while maintaining superb balance and control. The powerful, precision motor ensures fast and consistent installation of fasteners in a variety of applications, and the wide selection of speeds and threads in both English and metric sizes make Sioux Tools your choice for all your clinch nut applications.

www.dobcoeqp.com
sales@dobcoeqp.com
905-672-5557

DOBCO EQUIPMENT LTD.
905-672-5557
sales@dobcoeqp.com
www.dobcoeqp.com

COMPRESSION RIVETERS

C-Yoke Type



SZE A3015



SZE A6015



SZE A8015

| Model Number | Rivet Set Shank Diameter | | Cap. Cold Rivet Diameter | | | | Standard Alligator "C" Dimension | | | | Closed Height | | Max Travel | | Max Force at 90 psi | | Stroke at Max Force | | Net Weight w/Yoke | | Overall Length | |
|-------------------------------|--------------------------|-----|--------------------------|---|------|---|----------------------------------|-----|-------|-----|---------------|-----|------------|----|---------------------|------|---------------------|----|-------------------|-----|----------------|-----|
| | in | mm | Steel | | Alum | | Reach | | Gap | | in | mm | in | mm | lb | kN | in | mm | lb | kg | in | mm |
| CR-1 — Single Cylinder | | | | | | | | | | | | | | | | | | | | | | |
| SZE A3000 | N/A | N/A | 3/32 | 2 | 1/8 | 3 | N/A | N/A | N/A | N/A | N/A | N/A | 9/16 | 14 | 3000 | 13.4 | f-1/16 | 2 | 3-1/2 | 1.6 | 8-1/2 | 216 |
| SZE A3015 | 3/16 | 5 | 3/32 | 2 | 1/8 | 3 | 1-1/2 | 38 | 1-1/4 | 32 | 11/16 | 78 | 9/16 | 14 | 3000 | 13.4 | f-1/16 | 2 | 4-1/2 | 2.0 | 10-1/4 | 262 |
| CR-1 — Tandem Cylinder | | | | | | | | | | | | | | | | | | | | | | |
| SZE A6000 | N/A | N/A | 5/32 | 4 | 3/16 | 5 | N/A | N/A | N/A | N/A | N/A | N/A | 9/16 | 14 | 6000 | 26.7 | f-1/16 | 2 | 4-1/2 | 2.0 | 11-1/4 | 287 |
| SZE A6015 | 3/16 | 5 | 5/32 | 4 | 3/16 | 5 | 1-1/2 | 38 | 1-1/4 | 32 | 11/16 | 78 | 9/16 | 14 | 6000 | 26.7 | f-1/16 | 2 | 5-1/2 | 2.5 | 14 | 356 |
| CR-1 — Triple Cylinder | | | | | | | | | | | | | | | | | | | | | | |
| SZE A8000 | N/A | N/A | 5/32 | 4 | 1/4 | 6 | N/A | N/A | N/A | N/A | N/A | N/A | 9/16 | 14 | 9000 | 40.1 | f-1/16 | 2 | 7-1/2 | 3.4 | 16 | 406 |
| SZE A8015 | 3/16 | 5 | 3/16 | 5 | 1/4 | 6 | 1-1/2 | 38 | 1-1/4 | 32 | 11/16 | 78 | 9/16 | 14 | 9000 | 40.1 | f-1/16 | 2 | 8-1/2 | 3.9 | 18-3/4 | 476 |

C-Yoke Nomenclature

- A Reach
- B Gap
- C Height from yoke hole to center to top of yoke gap
- D Bottom set hole diameter CR-1 or CR-2
- E Top set hole diameter CR-1 or CR-2
- F Width of yoke set hole center to top of yoke
- G Thickness of yoke
- H Height of yoke from bolt hole center to top of yoke
- I Radius from set hole center

| A | | B | | C | | D | | E | | F | | G | | H | | I | |
|-------|----|-------|----|-------|----|------|----|------|----|-------|----|------|----|-----|----|-----|----|
| in | mm | in | mm | in | mm | in | mm | in | mm | in | mm | in | mm | in | mm | in | mm |
| 1-1/2 | 38 | 1-1/4 | 32 | 1-7/8 | 48 | 3/8 | 10 | 3/16 | 5 | 2-7/8 | 73 | 9/16 | 14 | 3.0 | 76 | 1/4 | 6 |
| | | | | | | 7/16 | 11 | 1/4 | 6 | | | | | | | | |

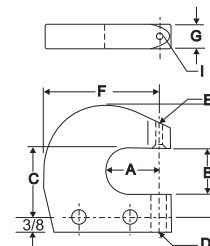

Alligator Yoke Type



SZE A5030



SZE A7030



SZE A9030

| Model Number | Rivet Set Shank Diameter | | Cap. Cold Rivet Diameter | | | | Standard Alligator Yoke Dimension | | | | Max Force at 90 psi | | Moving Jaw | | | | Net Weight w/ Yoke | | Overall Length | |
|-------------------------------|--------------------------|----|--------------------------|----|-------|----|-----------------------------------|----|------------|----|---------------------|------|--------------------|----|----------------|----|--------------------|------|----------------|-----|
| | Steel | | Alum | | Reach | | Closed Ht | | Max Travel | | Stroke at Max Force | | Net Weight w/ Yoke | | Overall Length | | | | | |
| | in | mm | in | mm | in | mm | in | mm | in | mm | in | mm | in | mm | lb | kg | in | mm | | |
| CR-1 — Single Cylinder | | | | | | | | | | | | | | | | | | | | |
| SZE A5000 | NA | NA | 3/32 | 2 | 1/8 | 3 | NA | NA | NA | NA | 3000 | 13.4 | 5/8 | 16 | final 1/16 | 2 | 2-1/4 | 1.0 | 7-11/16 | 195 |
| SZE A5015 | 3/16 | 5 | 3/32 | 2 | 1/8 | 3 | 1-1/2 | 38 | 7/8 | 22 | 3000 | 13.4 | 5/8 | 16 | final 1/16 | 2 | 3.75 | 1.7 | 9-3/16 | 233 |
| SZE A5022 | 3/16 | 5 | 3/32 | 2 | 3/32 | 2 | 2-1/4 | 57 | 7/8 | 22 | 2200 | 9.8 | 7/8 | 22 | final 3/32 | 2 | 4.25 | 1.9 | 10-1/8 | 257 |
| SZE A5030 | 3/16 | 5 | 3/32 | 2 | 3/32 | 2 | 3 | 76 | 7/8 | 22 | 1800 | 8.0 | 1-1/4 | 32 | final 1/8 | 3 | 4.75 | 2.2 | 10-7/8 | 276 |
| CR-1 — Tandem Cylinder | | | | | | | | | | | | | | | | | | | | |
| SZE A7000 | NA | | 5/32 | 4 | 3/16 | 5 | NA | NA | NA | NA | 6000 | 26.7 | 5/8 | 16 | final 1/16 | 2 | 4 | 1.8 | 10-1/2 | 267 |
| SZE A7015 | 3/16 | 5 | 5/32 | 4 | 3/16 | 5 | 1-1/2 | 38 | 7/8 | 22 | 6000 | 26.7 | 5/8 | 16 | final 1/16 | 2 | 5.5 | 2.5 | 12 | 305 |
| SZE A7022 | 3/16 | 5 | 1/8 | 3 | 5/32 | 4 | 2-1/4 | 57 | 7/8 | 22 | 4300 | 19.1 | 7/8 | 22 | final 3/32 | 2 | 6 | 2.7 | 13 | 330 |
| SZE A7030 | 3/16 | 5 | 3/32 | 2 | 1/8 | 3 | 3 | 76 | 7/8 | 22 | 3400 | 15.1 | 1-1/4 | 32 | final 1/8 | 3 | 6.25 | 2.8 | 13.75 | 349 |
| CR-1 — Triple Cylinder | | | | | | | | | | | | | | | | | | | | |
| SZE A9000 | NA | NA | 3/16 | 5 | 1/4 | 6 | NA | NA | NA | NA | 9000 | 40.1 | 5/8 | 16 | final 1/16 | 2 | 5.5 | 2.5 | 14.5 | 368 |
| SZE A9015 | 3/16 | 5 | 3/16 | 5 | 1/4 | 6 | 1-1/2 | 38 | 7/8 | 22 | 9000 | 40.1 | 5/8 | 16 | final 1/16 | 2 | 7 | 3.2 | 16 | 406 |
| SZE A9022 | 3/16 | 5 | 5/32 | 4 | 3/16 | 5 | 2-1/4 | 57 | 7/8 | 22 | 7000 | 31.2 | 7/8 | 22 | final 3/32 | 2 | 7.5 | 93.4 | 16.75 | 426 |
| SZE A9030 | 3/16 | 5 | 5/32 | 4 | 3/16 | 5 | 3 | 76 | 7/8 | 22 | 5200 | 23.1 | 1-1/4 | 32 | final 1/8 | 3 | 8 | 3.6 | 17.5 | 445 |

Alligator Yoke Nomenclature

- A Reach
- B Closed Height
- C Total
- E Gap
- H Lowest Offset
- N Depth from centerline to Stationary Jaw Gap
- P Depth from centerline to Stationary Jaw set hole surface

| A | | B | | C | | E | | H | | N | | P | |
|-------|----|-----|----|-------|----|-------|----|------|----|-------|----|-----|----|
| in | mm | in | mm | in | mm | in | mm | in | mm | in | mm | in | mm |
| 1-1/2 | 38 | 7/8 | 22 | 1-1/2 | 38 | 1-5/8 | 41 | 7/32 | 6 | 1.0 | 1 | 5/8 | 16 |
| 2-1/4 | 57 | 7/8 | 22 | 1-7/8 | 48 | 2-1/8 | 54 | 7/32 | 6 | 1-1/4 | 32 | 5/8 | 16 |
| 3.0 | 76 | 7/8 | 22 | 2-1/8 | 54 | 2-1/8 | 54 | 7/32 | 6 | 1-1/4 | 32 | 5/8 | 16 |

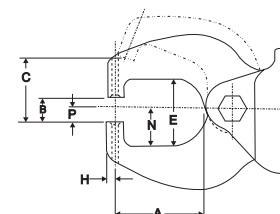

Dustless Wet/Dry Vacuum Sioux Model DVS-5

Dustless HEPA Vacuum Sioux Model DVH-3



- Outperforms Traditional Shop Vacs
- Two Layers Of Filtration For A Dust-Free Environment
- Powerful 23,000 RPM, 11.5 Amp Electric Motor
- 16 Gallon Capacity
- Does Not Cough Dust When Vacuum Is Turned On
- Convenient Tool Storage Onboard Vacuum
- Filtration Down To .5 Microns
- Quiet Operation Only 81 dB(A)



- HEPA Certified
- Filtration Down To .3 Microns
- 16 Gallon Capacity
- Designed For Extra Fine Dust
- Quiet Operation Only 81 dB(A)
- Great For Hexavalent Chromium Applications

Random Orbital Sander Vacuum Shroud Sioux Models R025VS-5 and R025VS-6

- Fit R025 Series Random Orbital Sanders
- Available For 5" Or 6" Sanders
- Captures 99% Of Airborne Dust
- Protects Workers From Harmful Airborne Dust
- Flexible And Transparent For Better Visibility
- Includes 6 Ft. Vacuum Hose



Vacuum Shroud Part Numbers

| | |
|----------|------------------|
| R025VS-5 | 5" Vacuum Shroud |
| R025VS-6 | 6" Vacuum Shroud |

Drill and Rivet Shaver Vacuum Shroud Sioux Model DRVS150

- Can Be Used With Any Drill Or Suction Holds The Shroud In Place
- Great For Tight Spaces
- Can Be Used For Drilling Holes Up To 1 3/8" Diameter
- Captures 99% Of Airborne Dust
- Protects Workers From Harmful Airborne Dust
- Transparent For Better Visibility
- Includes 6 Ft. Vacuum Hose



Distributed By:

Dobco Equipment Limited
1-2430 Lucknow Drive,
Mississauga, Ontario
L5S 1V3 Canada

905.672.5557

sales@dobcoeqp.com