





Vertical Tools					
Page Number	Application	Abrasive Size	Model Series	Power Output	Mounting of Abrasives
7	Type 27, Type 27 Cut-Off (Type 42) & 28 Depressed Center Wheels	7 Inch (180 mm)	520V	2 H.P. (1.5 kW)	<p>Type 27 Wheel w/o Hub Wheel Safety Guard Adapter Wheel Adapter Nut CP-51 CP-52</p>
		7 Inch (180 mm)	54V	3 H.P. (2.3 kW)	
		9 Inch (230 mm)			
8	Type 27 Wheel with Built-in Adapter Type 27 Wheel without Built-in Adapter	7 Inch (180 mm)	64V	4 H.P. (3.0 kW)	
		9 Inch (230 mm)			
		9 Inch (230 mm)	727V	4.3 H.P. (3.2 kW)	
9	Type 11 Cup Wheels	4 Inch (100 mm)	520V	2 H.P. (1.5 kW)	<p>*The use of Wheel Safety Retainers is highly recommended with cup wheels. Wheel Safety Retainer* Wheel Safety Guard Wheel</p>
		4 Inch (100 mm)	58C	3 H.P. (2.3 kW)	
10	Type 11 Wheel Cup Wheel Maximum Height is 2.0 inches (50mm).	6 Inch (150 mm)	68C	4 H.P. (3.0 kW)	
		6 Inch (150 mm)	711C	4.3 H.P. (3.2 kW)	
11	Type 1 Cut-Off (Type 41) Bonded or Diamond Wheels	8 Inch (200 mm)	56PC	3 H.P. (2.3 kW)	<p>8" or 10" Size Wheels Inner Wheel Flange Wheel Nut Wheel Safety Guard Wheel Outer Wheel Flange 12" or 14" Size Wheels Inner Wheel Flange Wheel Nut Wheel Safety Guard Wheel Outer Wheel Flange</p>
		10 Inch (250 mm)			
		12 Inch (300 mm)	66PC	4 H.P. (3.0 kW)	
		14 Inch (350 mm)			
12	Surface Conditioning or Sanding Abrasives	7 Inch (180 mm)	520V	2 H.P. (1.5 kW)	<p>Backing Pad Sanding Pad Nut Abrasive Disc</p>
		7 Inch (180 mm)	56S	3 H.P. (2.3 kW)	
		9 Inch (230 mm)	56S	3 H.P. (2.3 kW)	

HANDLES

Several different handle styles are offered on our vertical tools. Pictured below are each in detail.



(L) Regular Lever



(K) Safety Lever



(B) Thumb Switch

SPEED/GUARD SIZE SELECTION

The rated speed and guard size are closely linked to promote safety and maximize efficiency of the grinding operation. Each model offers various options that are specific to the size/type of the abrasive.

MOUNTING OF ABRASIVES

Each wheel type mounts onto the tool in a specific way. Please consult the diagrams above for details on how your particular wheel mounts onto the tool. More details on the mounting of wheels can be found in ANSI B7.1 and ANSI B186.1. Mounting wheels in ways other than those shown are non-compliant and may lead to injury.



Depressed Center Type 27 Wheel



Depressed Center Type 27 Cut-Off (Type 42) Wheel

7 Inch • 9 Inch Diameter Wheels
(180 mm) (230 mm)

Vertical Grinders for use with Type 27, Type 27 Cut-Off (Type 42) & 28 Depressed Center Wheels

520V Series



520VK;8000;727

54V Series

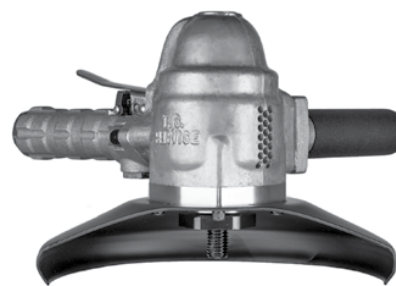

54VK;6000;927

Wheel Size	Operating Speed	Lever Style	MODEL NUMBER	Wheel Size	Operating Speed	Lever Style	MODEL NUMBER
7 Inch (180 mm)	8000 RPM	Standard Lever	520VL;8000;727	7 Inch (180 mm)	8000 RPM	Standard Lever	54VL;8000;727
		Safety Lever	520VK;8000;727			Safety Lever	54VK;8000;727
		Standard Lever		9 Inch (230 mm)	6000 RPM	Standard Lever	54VL;6000;927
		Safety Lever				Safety Lever	54VK;6000;927

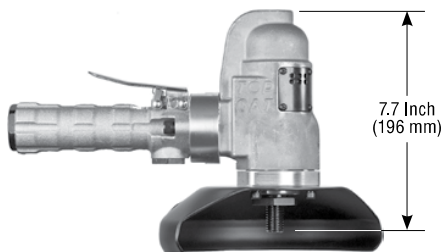

7.7 Inch (196 mm)

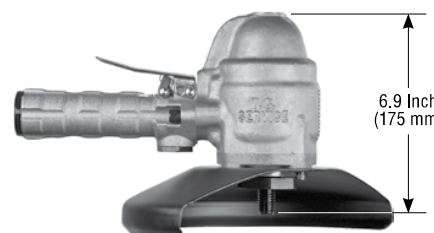

6.9 Inch (175 mm)

HP 2.0 H.P. (1.5 kW)
Lbs 7.4 Lbs. (3.3 Kg)

cfm 20 cfm (9.4 L/s) Free Speed
40 cfm (18.9 L/s) Max
SUPPLY 1/2" NPT Inlet
1/2" (13 mm) Hose Size

HP 3.0 H.P. (2.3 kW)
Lbs 9.8 Lbs. (4.4 Kg)

cfm 25 cfm (18.8 L/s) Free Speed
60 cfm (28.3 L/s) Max
SUPPLY 1/2" NPT Inlet
1/2" (13 mm) Hose Size



Piped Away Exhaust Available to Reduce Sound Emissions.

STANDARD EQUIPMENT

- Tool
- Operating Instructions and Service Manual
- Wrenches (sizes based on options)

ALTERNATE OPTIONS

Operating Speed



The tools above can be rated at speeds slower than 8000 RPM when used with a 7 Inch (180 mm) wheel.

Handles



Thumb Switch Safety Lever Standard Lever

WHEEL MOUNTING

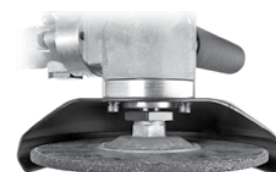

Type 27 or Type 27 Cut-Off (Type 42)
The depressed center wheel adapters are not supplied as standard equipment with the tools. If you are using a wheel that requires the adapters, they must be purchased separately.

WARNING: Follow all recommendations from component and abrasive manufacturers for speeds and proper usage.



Depressed Center Type 27 Wheel



Depressed Center Type 27 Cut-Off (Type 42) Wheel

7 Inch • 9 Inch Diameter Wheels
(180 mm) (230 mm)

Vertical Grinders for use with Type 27, Type 27 Cut-Off (Type 42) & 28 Depressed Center Wheels

64V Series



64VK;6000;927

727V Series Coming Soon!



727VK;6000;927

Wheel Size	Operating Speed	Lever Style	MODEL NUMBER
7 Inch (180 mm)	8000 RPM	Standard Lever	64VL;8000;727
		Safety Lever	64VK;8000;727
9 Inch (230 mm)	6000 RPM	Standard Lever	64VL;6000;927
		Safety Lever	64VK;6000;927

Wheel Size	Operating Speed	Lever Style	MODEL NUMBER
9 Inch (230 mm)	6000 RPM	Standard Lever	727VL;6000;927
		Safety Lever	727VK;6000;927



7.4 Inch (188 mm)

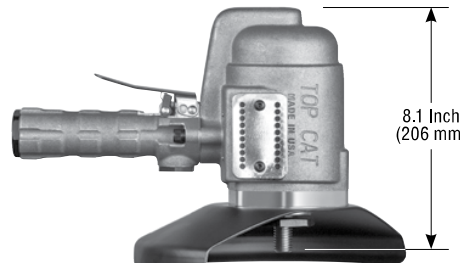

8.1 Inch (206 mm)



4.0 H.P. (3.0 kW)



25 cfm (18.8 L/s) Free Speed
75 cfm (35.4 L/s) Max



11.3 Lbs. (5.1 Kg)



1/2" NPT Inlet
1/2" (13 mm) Hose Size



4.3 H.P. (3.2 kW)



25 cfm (18.8 L/s) Free Speed
85 cfm (40.1 L/s) Max



12.8 Lbs. (5.8 Kg)



1/2" NPT Inlet
1/2" (13 mm) Hose Size



Piped Away Exhaust Available to Reduce Sound Emissions.

STANDARD EQUIPMENT

- Tool
- Operating Instructions and Service Manual
- Wrenches (sizes based on options)

ALTERNATE OPTIONS

Operating Speed



The tools above can be rated at speeds slower than 8000 RPM when used with a 7 Inch (180 mm) wheel.

Handles



Thumb Switch Safety Lever Standard Lever

WHEEL MOUNTING

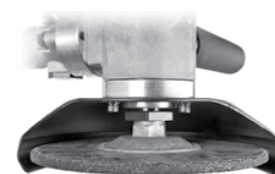

Type 27 or Type 27 Cut-Off (Type 42)
The depressed center wheel adapters are not supplied as standard equipment with the tools. If you are using a wheel that requires the adapters, they must be purchased separately.



4 Inch • 6 Inch Diameter Wheels
(100 mm) (150 mm)

VERTICAL TOOLS

Vertical Grinders for use with Type 11 Cup Wheels

520V Series



520VK;8000;411

58C Series

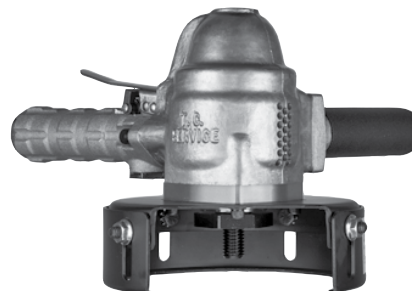

58CK;6000;611

Wheel Size	Operating Speed	Lever Style	MODEL NUMBER	Wheel Size	Operating Speed	Lever Style	MODEL NUMBER
4 Inch (100 mm)	8000 RPM	Standard Lever	520VL;8000;411	4 Inch (100 mm)	8000 RPM	Standard Lever	58CL;8000;411
		Safety Lever	520VK;8000;411			Safety Lever	58CK;8000;411
				6 Inch (150 mm)	6000 RPM	Standard Lever	58CL;6000;611
						Safety Lever	58CK;6000;611

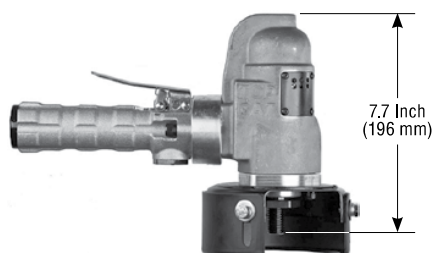

HP 2.0 H.P. (1.5 kW)

Lbs 7.5 Lbs. (3.4 Kg)

cfm 20 cfm (9.4 L/s) Free Speed
40 cfm (18.9 L/s) Max

SUPPLY 1/2" NPT Inlet
1/2" (13 mm) Hose Size

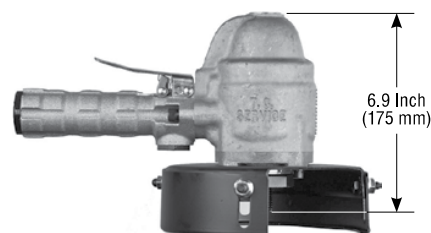

HP 3.0 H.P. (2.3 kW)

Lbs 10.3 Lbs. (4.7 Kg)

cfm 25 cfm (18.8 L/s) Free Speed
60 cfm (28.3 L/s) Max

SUPPLY 1/2" NPT Inlet
1/2" (13 mm) Hose Size



Piped Away Exhaust Available to Reduce Sound Emissions.

STANDARD EQUIPMENT

- Tool
- Operating Instructions and Service Manual
- Wrenches (sizes based on options)

ALTERNATE OPTIONS



Versions are Available on Model 58C for use with 5 Inch (125 mm) Wheels.

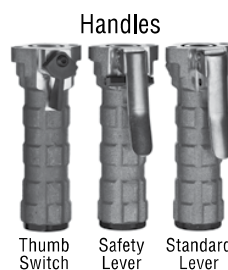

WHEEL MOUNTING



Type 11 Wheel



4 Inch • 6 Inch Diameter Wheels
(100 mm) (150 mm)

Vertical Grinders for use with Type 11 Cup Wheels

68C Series

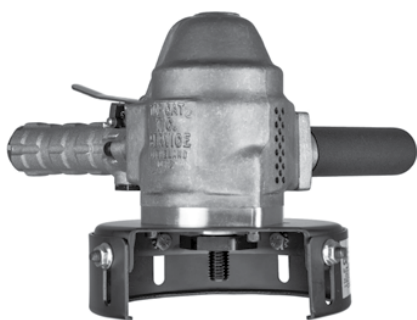

68CK;6000;611

711C Series *Coming Soon!*

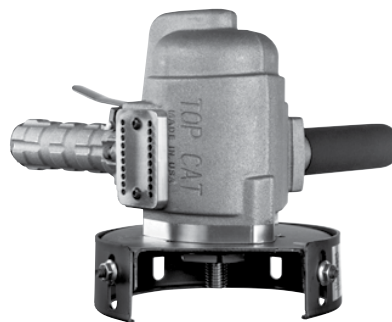

711CK;6000;611

Wheel Size	Operating Speed	Lever Style	MODEL NUMBER	Wheel Size	Operating Speed	Lever Style	MODEL NUMBER
6 Inch (150 mm)	6000 RPM	Standard Lever	68CL;6000;611	6 Inch (150 mm)	6000 RPM	Standard Lever	711CL;6000;611
		Safety Lever	68CK;6000;611			Safety Lever	711CK;6000;611

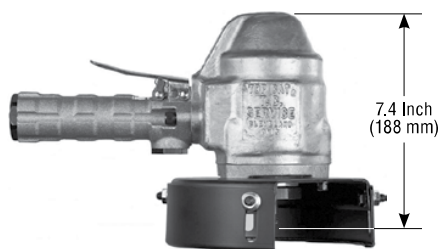

7.4 Inch (188 mm)

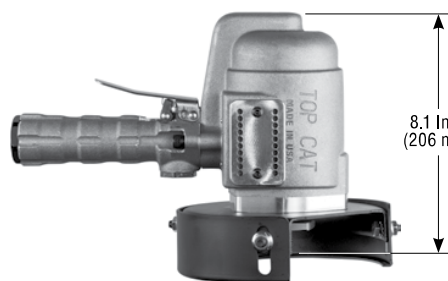

8.1 Inch (206 mm)



4.0 H.P. (3.0 kW)



25 cfm (18.8 L/s) Free Speed
75 cfm (35.4 L/s) Max



11.8 Lbs. (5.3 Kg)



1/2" NPT Inlet
1/2" (13 mm) Hose Size



4.3 H.P. (3.2 kW)



25 cfm (18.8 L/s) Free Speed
85 cfm (40.1 L/s) Max



13.3 Lbs. (6.0 Kg)



1/2" NPT Inlet
1/2" (13 mm) Hose Size



Piped Away Exhaust Available to Reduce Sound Emissions.

STANDARD EQUIPMENT

- Tool
- Operating Instructions and Service Manual
- Wrenches (sizes based on options)

ALTERNATE OPTIONS



Wheel Size

Versions are Available on Model 68C for use with 5 Inch (125 mm) Wheels.

Handles



Thumb Switch Safety Lever Standard Lever

WHEEL MOUNTING



Type 11 Wheel



8 Inch • 10 Inch • 12 Inch • 14 Inch Diameter Wheels
 (200 mm) (250 mm) (300 mm) (350 mm)

VERTICAL TOOLS

Pile Cutters for use with Bonded Type 1 Cut-off (Type 41) or Diamond Wheels

56PC Series



56PCK;6000;841

66PC Series



66PCK;4000;1441

Wheel Size	Operating Speed	Lever Style	MODEL NUMBER	Wheel Size	Operating Speed	Lever Style	MODEL NUMBER	
8 Inch X 5/8 ID (200 mm)	6000 RPM	Standard Lever	56PCL;6000;841	10 Inch X 5/8 ID (250 mm)	6000 RPM	Standard Lever	66PCL;6000;1041	
		Safety Lever	56PCK;6000;841			Safety Lever	66PCK;6000;1041	
12 Inch X 1.0 ID (300 mm)	5000 RPM	Standard Lever	66PCL;5000;1241		12 Inch X 1.0 ID (300 mm)	5000 RPM	Standard Lever	66PCL;5000;1241
		Safety Lever	66PCK;5000;1241				Safety Lever	66PCK;5000;1241
14 Inch X 1.0 ID (350 mm)	4000 RPM	Standard Lever	66PCL;4000;1441		14 Inch X 1.0 ID (350 mm)	4000 RPM	Standard Lever	66PCL;4000;1441
		Safety Lever	66PCK;4000;1441				Safety Lever	66PCK;4000;1441



7.2 Inch
(183 mm)



3.0 H.P.
(2.3 kW)



25 cfm (18.8 L/s) Free Speed
60 cfm (28.3 L/s) Max



11.3 Lbs.
(5.1 Kg)



1/2" NPT Inlet
1/2" (13 mm) Hose Size



7.6 Inch
(193 mm)



4.0 H.P.
(3.0 kW)



25 cfm (18.8 L/s) Free Speed
75 cfm (35.4 L/s) Max



15.8 Lbs.
(7.2 Kg)



1/2" NPT Inlet
1/2" (13 mm) Hose Size

STANDARD EQUIPMENT

- Tool
- Operating Instructions and Service Manual
- Wrenches (sizes based on options)

ALTERNATE OPTIONS

Handles



Thumb Switch Safety Lever Standard Lever

WHEEL MOUNTING



WARNING: Follow all recommendations from component and abrasive manufacturers for speeds and proper usage.

www.dobcoeqp.com sales@dobcoeqp.com 905-672-5557 DOBCO EQUIPMENT LTD.

DOBCO EQUIPMENT LTD. 905-672-5557 sales@dobcoeqp.com www.dobcoeqp.com



7 Inch • 9 Inch Sanding Abrasives
(180 mm) (230 mm)

Vertical Sanders for use with Surface Conditioning Abrasives

520V Series



520VK;8000;7SP

56S Series



56SK;6000;7SP

Wheel Size	Operating Speed	Lever Style	MODEL NUMBER
7 Inch (180 mm)	6000 RPM	Standard Lever	520VL;6000;7SP
		Safety Lever	520VK;6000;7SP
	8000 RPM	Standard Lever	520VL;8000;7SP
		Safety Lever	520VK;8000;7SP

Wheel Size	Operating Speed	Lever Style	MODEL NUMBER
7 Inch (180 mm)	6000 RPM	Standard Lever	56SL;6000;7SP
		Safety Lever	56SK;6000;7SP
	8000 RPM	Standard Lever	56SL;8000;7SP
		Safety Lever	56SK;8000;7SP
9 Inch (230 mm)	6000 RPM	Standard Lever	56SL;6000;9SP
		Safety Lever	56SK;6000;9SP



2.0 H.P.
(1.5 kW)



20 cfm (9.4 L/s) Free Speed
40 cfm (18.9 L/s) Max



6.8 Lbs.
(3.1 Kg)



1/2" NPT Inlet
1/2" (13 mm) Hose Size



3.0 H.P.
(2.3 kW)



25 cfm (18.8 L/s) Free Speed
60 cfm (28.3 L/s) Max



8.8 Lbs.
(4.0 Kg)



1/2" NPT Inlet
1/2" (13 mm) Hose Size

STANDARD EQUIPMENT

- Tool
- Operating Instructions and Service Manual
- Wrenches (sizes based on options)

ALTERNATE OPTIONS

Handles



Thumb Switch Safety Lever Standard Lever

ABRASIVE MOUNTING



Sanding Disc