

www.dobcoeqp.com

sales@dobcoeqp.com

905-672-5557

DOBCO EQUIPMENT LTD.

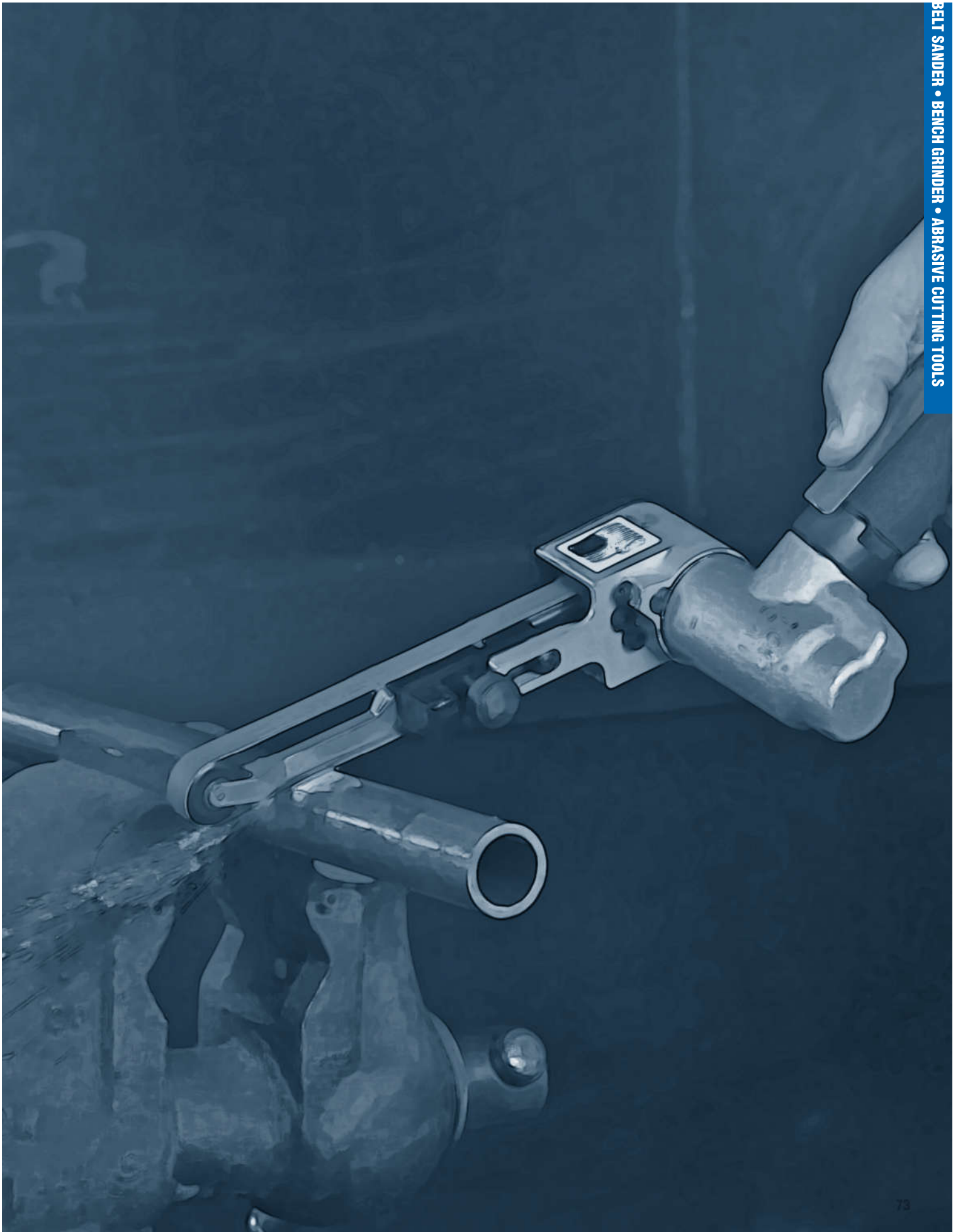

BELT SANDER • BENCH GRINDER • ABRASIVE CUTTING TOOLS

DOBCO EQUIPMENT LTD.

905-672-5557

sales@dobcoeqp.com

www.dobcoeqp.com



# Belt Sander

## 300BL/K

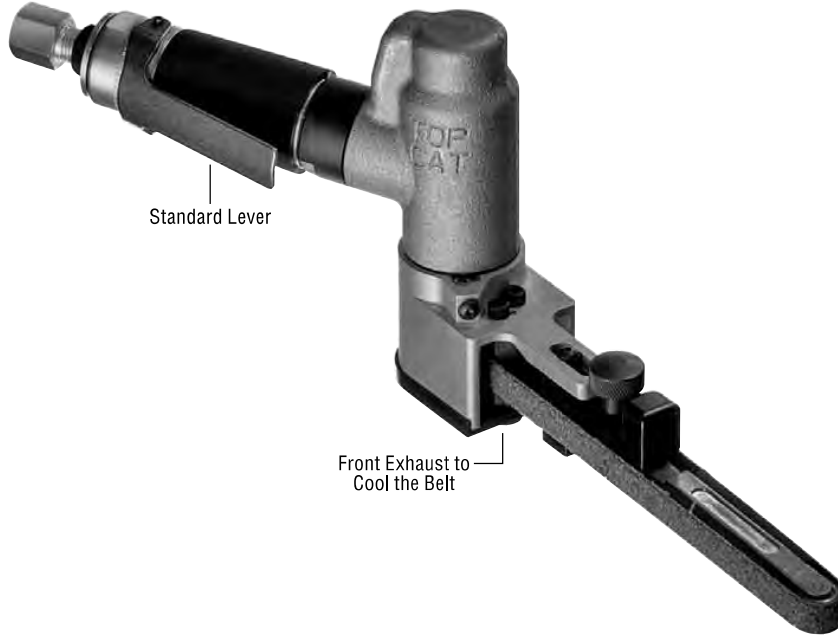

Belt Capacity	Max. SFPM	Lever Style	Model Number
5/8 or 3/4 Inch X 18 Inch	5700 SFPM	Standard Lever	300BL
		Safety Lever	300BK

The 300B Series is offered in a version with a 4550 Max SFPM.

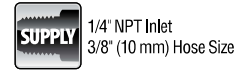
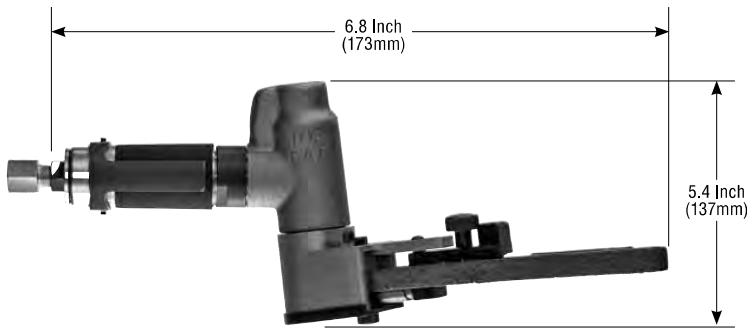

### STANDARD EQUIPMENT

- Tool
- Operating Instructions and Service Manual
- Wrenches (sizes based on options)



### Bench Grinder

66BVG



Adjustable Spark Arrestor

Adjustable Work Rest

MODEL NUMBER

66BVG;6000;9

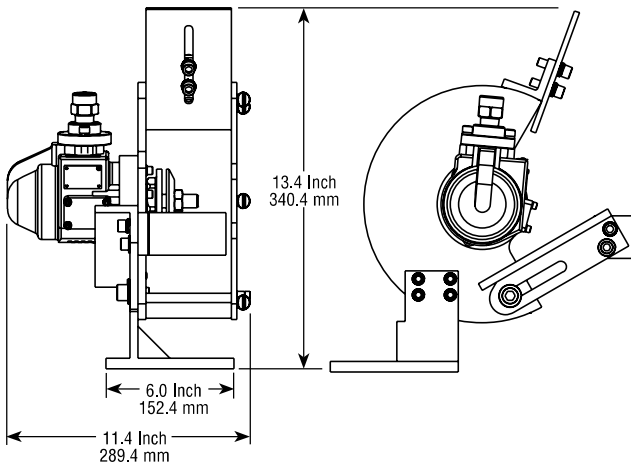

**HP** 4.0 H.P. (3000 W)

**Lbs** 51.0 Lbs (23.0 Kg)

**cfm** 25 cfm (11.8 L/s) Free  
75 cfm (35.4 L/s) Max

**SUPPLY** 1/2" NPT Inlet  
1/2" (13mm) Hose Size

#### STANDARD EQUIPMENT

- Tool
- Operating Instructions and Service Manual
- Wrenches (sizes based on options)



Reinforced Type 1 Cut-Off Wheel (Type 41)



Diamond Wheel

### Abrasive Cutting Tools



65VBW;5000;12

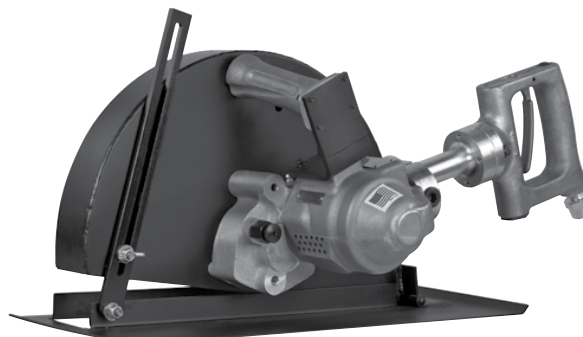

662VBW;3300;14

Guard Size	Spindle Type	Operating Speed	MODEL NUMBER	Guard Size	Spindle Type	Operating Speed	MODEL NUMBER
9 Inch	5/8-11	6000 RPM	65VBW;6000;941				
12 Inch	1" Spline	5000 RPM	65VBW;5000;1241	12 Inch	1" Spline	3300 RPM	662VBW;3300;1241
14 Inch		4000 RPM	65VBW;4000;1441	14 Inch			662VBW;3300;1441

Dimensions shown are for 12" guard. Other guards vary slightly.

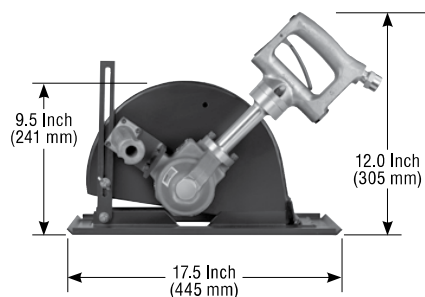

Dimensions shown are for 14" guard. Other guards vary slightly.

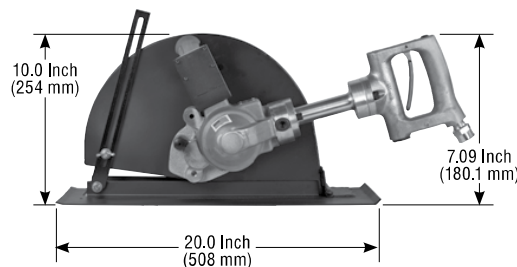

4.0 H.P.  
(3000 W)



25 cfm (11.8 L/s) Free  
75 cfm (35.4 L/s) Max



65VBW: 23.9 Lbs. (10.8 Kg)  
662VBW: 28.3 Lbs. (12.8 Kg)



1/2" NPT Inlet  
1/2" (13mm) Hose Size

#### STANDARD EQUIPMENT

- Tool
- Operating Instructions and Service Manual
- Wrenches (sizes based on options)

Model Number	Depth of Cut		
	Guard Size		
	9 Inch (230mm)	12 Inch (300mm)	14 inch (360mm)
65VBW	2.5 Inch (64mm)	3.3 Inch (84mm)	4.3 Inch (109mm)
662VBW	N/A		



Wet Cutting Attachment